

DIN 352

NO/CS/WS
code 114 XXX

HSS
code 144 XXX

Závitníky sadové Set of hand taps Satzgewindebohrer Метчики наборные

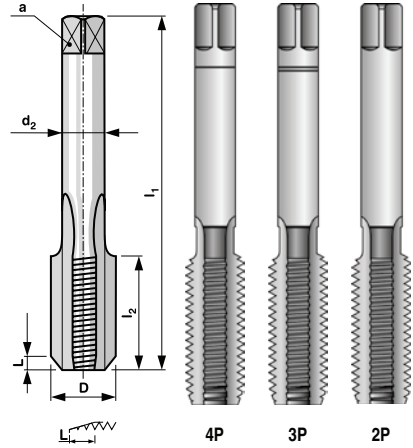
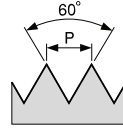
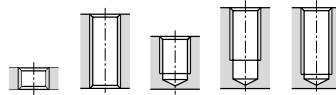

Lícování: 2N / Tolerance: 2N /
Toleranz: 2N / Подгонка: 2N

M

Metrický závit
Standard metric thread
Metrische Regelgewinde
Метрическая резьба

D	P	l ₁	l ₂	d ₂	a		*	code NO/CS/WS	code HSS
M 1	0,25	32	5,5	2,5	2,1	0,75	3		144 010
M 1,1	0,25	32	5,5	2,5	2,1	0,85	3		144 011
M 1,2	0,25	32	5,5	2,5	2,1	0,95	3		144 012
M 1,4	0,3	32	7	2,5	2,1	1,10	3		144 014
M 1,6	0,35	32	8	2,5	2,1	1,25	3		144 016
M 1,7	0,35	32	8	2,5	2,1	1,35	3		144 017
M 1,8	0,35	32	8	2,5	2,1	1,45	3		144 018
M 2	0,4	36	8	2,8	2,1	1,60	3	114 020	144 020
M 2,2	0,45	36	9	2,8	2,1	1,75	3	114 022	144 022
M 2,5	0,45	40	9	2,8	2,1	2,05	3	114 025	144 025
M 3	0,5	40	11	3,5	2,7	2,50	3	114 030	144 030
M 3,5	0,6	45	13	4	3	2,90	3	114 035	144 035
M 4	0,7	45	13	4,5	3,4	3,30	3	114 040	144 040
M 4,5	0,75	50	16	6	4,9	4,00	3	114 045	144 045
M 5	0,8	50	16	6	4,9	4,20	3	114 050	144 050
M 6	1	50	19	6	4,9	5,00	3	114 060	144 060
M 7	1	50	19	6	4,9	6,00	3	114 070	144 070
M 8	1,25	56	22	6	4,9	6,80	3	114 080	144 080
M 9	1,25	63	22	7	5,5	7,80	3	114 090	144 090
M 10	1,5	70	24	7	5,5	8,50	3	114 100	144 100
M 11	1,5	70	24	8	6,2	9,50	3	114 110	144 110
M 12	1,75	75	29	9	7	10,20	3	114 120	144 120
M 14	2	80	30	11	9	12,00	3	114 140	144 140
M 16	2	80	30	12	9	14,00	3	114 160	144 160
M 18	2,5	95	30	14	11	15,50	3	114 180	144 180
M 20	2,5	95	32	16	12	17,50	3	114 200	144 200
M 22	2,5	100	32	18	14,5	19,50	3	114 220	144 220
M 24	3	110	34	18	14,5	21,00	3	114 240	144 240
M 27	3	110	36	20	16	24,00	3	114 270	144 270
M 30	3,5	125	40	22	18	26,50	3	114 300	144 300
M 33	3,5	125	40	25	20	29,50	3		144 330
M 36	4	150	50	28	22	32,00	3		144 360
M 39	4	150	50	32	24	35,00	3		144 390
M 42	4,5	150	56	32	24	37,50	3		144 420
M 45	4,5	160	58	36	29	40,50	3		144 450
M 48	5	180	65	36	29	43,00	3		144 480
M 52	5	180	65	40	32	37,00	3		144 520
M 56	5,5	180	70	40	32	50,50	3		144 560
M 60	5,5	200	70	45	35	54,50	3		144 600
M 64	6	220	75	50	39	58,00	3		144 640
M 68	6	220	75	50	39	62,00	3		144 680

* kusy v sadě / pcs in set / Stck in Satz / штук в наборе



BUČOVICE
TOOLS a.s.

Materiál: NO; HSS
Provedení: nebroušený závit
Závit: pravý

Material: CS-carbon steel;
HSS
Execution: non-ground thread
Thread: right-hand

Werkstoff: WS-Werkzeugstahl;
HSS
Ausführung: nicht
geschliffenes Gewinde
Gewinde: rechts

Материал: NO-инструментальная сталь; HSS
Изготовлено: нешлифованная резьба
Резьба: правая

DIN 2181

NO/CS/WS
code 114 XXX

HSS
code 144 XXX

Závitníky sadové Set of hand taps Satzgewindebohrer Метчики наборные

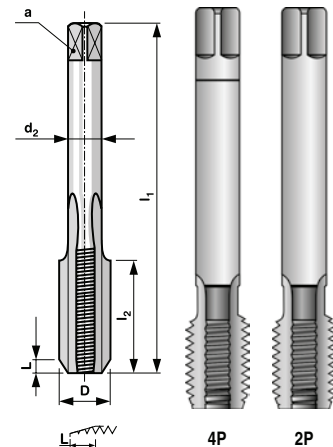
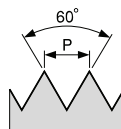
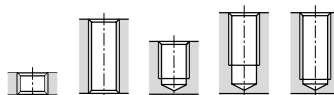

Jemný metrický závit
Fine metric thread
Metrische Feingewinde
Мелкая метрическая резьба

Licování: 2N / Tolerance: 2N /
Toleranz: 2N / Подгонка: 2N

MF

D	P	l ₁	l ₂	d ₂	a		*	code NO/CS/WS	code HSS
M 2,5	0,35	40	9	2,8	2,1	2,15	2	114 026	144 026
M 3	0,35	40	9	3,5	2,7	2,65	2	114 031	144 031
M 3,5	0,35	45	10	4,0	3,0	3,15	2	114 036	144 036
M 4	0,5	45	10	4,5	3,4	3,50	2	114 041	144 041
M 4,5	0,5	50	12	6,0	4,9	4,00	2	114 046	144 046
M 5	0,5	50	12	6,0	4,9	4,50	2	114 051	144 051
M 5,5	0,5	50	12	6,0	4,9	5,00	2	114 056	144 056
M 6	0,75	50	14	6,0	4,9	5,20	2	114 061	144 061
M 7	0,75	50	14	6,0	4,9	6,20	2	114 071	144 071
M 8	1	56	22	6,0	4,9	7,00	2	114 081	144 081
M 8	0,75	50	19	6,0	4,9	7,20	2	114 082	144 082
M 9	1	63	22	7,0	5,5	8,00	2	114 091	144 091
M 9	0,75	56	19	7,0	5,5	8,20	2	114 092	144 092
M 10	1,25	70	24	7,0	5,5	8,80	2	114 101	144 101
M 10	1	63	20	7,0	5,5	9,00	2	114 102	144 102
M 10	0,75	63	20	7,0	5,5	9,20	2	114 103	144 103
M 11	1	63	20	8,0	6,2	10,00	2	114 111	144 111
M 11	0,75	63	20	8,0	6,2	10,20	2	114 112	144 112
M 12	1,5	70	22	9,0	7,0	10,50	2	114 121	144 121
M 12	1,25	70	22	9,0	7,0	10,80	2	114 122	144 122
M 12	1	70	22	9,0	7,0	11,00	2	114 123	144 123
M 14	1,5	70	22	11	9,0	12,50	2	114 141	144 141
M 14	1,25	70	22	11	9,0	12,80	2	114 142	144 142
M 14	1	70	22	11	9,0	13,00	2	114 143	144 143
M 15	1	70	22	12	9,0	14,00	2	114 152	144 152
M 16	1,5	70	22	12	9,0	14,50	2	114 161	144 161
M 16	1	70	22	12	9,0	15,00	2	114 162	144 162
M 17	1	70	22	12	9,0	16,00	2	114 171	144 171
M 18	1,5	80	22	14	11,0	16,50	2	114 181	144 181
M 18	1	80	22	14	11,0	17,00	2	114 182	144 182
M 20	1,5	80	22	16	12,0	18,50	2	114 202	144 202
M 20	1	80	22	16	12,0	19,00	2	114 203	144 203
M 22	1,5	80	22	18	14,5	20,50	2	114 221	144 221
M 22	1	80	22	18	14,5	21,00	2	114 222	144 222
M 24	2	90	22	18	14,5	22,00	2	114 241	144 241
M 24	1,5	90	22	18	14,5	22,50	2	114 242	144 242
M 24	1	90	22	18	14,5	23,00	2	114 243	144 243
M 25	1,5	90	22	18	14,5	23,50	2	114 252	144 252
M 26	1,5	90	22	18	14,5	24,50	2	114 262	144 262
M 27	2	90	22	20	16	25,00	2	114 271	144 271
M 27	1,5	90	22	20	16	25,50	2	114 272	144 272
M 27	1	90	22	20	16	26,00	2	114 273	144 273
M 28	2	90	22	20	16	26,00	2	114 281	144 281
M 28	1,5	90	22	20	16	26,50	2	114 282	144 282
M 30	2	90	22	22	18	28,00	2	114 301	144 301
M 30	1,5	90	22	22	18	28,50	2	114 302	144 302
M 30	1	90	22	22	18	29,00	2	114 303	144 303
M 32	1,5	90	22	22	18	30,50	2		144 321
M 33	2	100	25	25	20	31,00	2		144 331
M 33	1,5	100	25	25	20	31,50	2		144 332
M 34	1,5	100	25	28	22	32,50	2		144 341
M 35	1,5	100	25	28	22	33,50	2		144 351
M 36	3	125	36	28	22	33,00	2		144 361
M 36	2	125	30	28	22	34,00	2		144 362
M 36	1,5	100	25	28	22	34,50	2		144 363
M 38	1,5	100	25	28	22	36,50	2		144 381
M 39	3	125	36	32	24	36,00	2		144 391
M 39	2	125	30	32	24	37,00	2		144 392
M 39	1,5	110	25	32	24	37,50	2		144 393
M 40	3	125	36	32	24	37,00	2		144 401

Materiál: NO: HSS
Provedení: nebroušený závit
Závit: pravý

Material: CS-carbon steel;
HSS
Execution: non-ground thread
Thread: right-hand

Werkstoff: WS-Werkzeugstahl;
HSS
Ausführung: nicht
geschliffenes Gewinde
Gewinde: rechts

Материал: NO-инструмен-
тальная сталь; HSS
Изготовлено:
нешлифованная резьба
Резьба: правая

BUČOVICE
TOOLS a.s.