

Standard Accessories

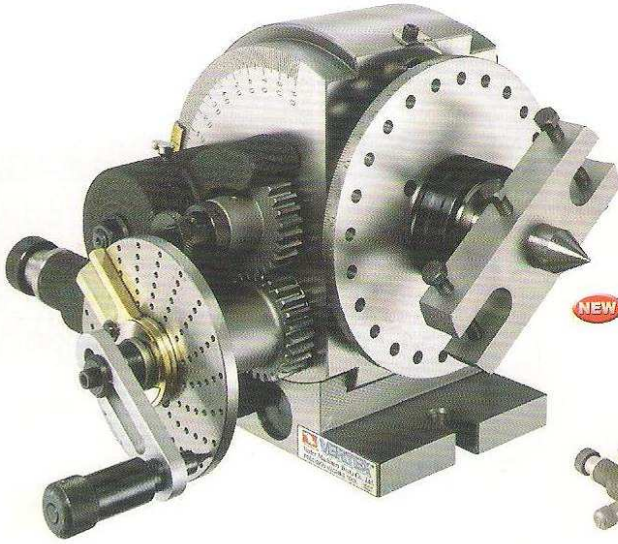

NEW MODEL FOR NEXT



NEW MODEL FOR NEXT



THREAD SPINDLE: 2 1/4" - 8TPI



BS-2-J IS BS-2 WITH 6" 3 JAW CHUCK & STANDARD ACCESSORIES

BS-2A

NEW



BS-2A COMES WITH A TAIL STOCK, A SET OF DIVIDING PLATE, A SET OF CARRIER CLAMP, A 3 JAW PLATE, A CENTER

BS-2A BODY STRUCTURE IS SAME AS BS-2 WITHOUT CHANGING GEAR ARBOR OR BRACKET. OTHER ACCESSORIES ARE SAME AS BS-2.

Standard Accessories

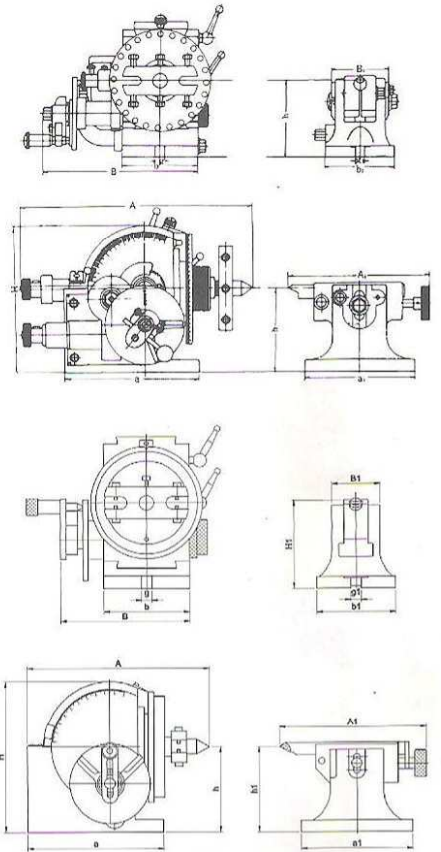

Universal Index No.2 (Head-stock):

Unit:mm/inches.

ORDER NO.	A	B	H	h	a	b	g	Taper of center	spindle hole
BS-2	365 14 13/32	272 10 45/64	236 9 13/64	132.7 5 15/64	213 5 25/64	134 5 9/32	16 5/8	MT-4	25.4 1
NEW BS-2A	285	202	237	134	213	134	16	MT-4	25.4

ORDER NO.	WEIGHT(kgs)	CODE NO.
BS-2	65	1001-052
BS-2-J-6	78.5	1001-055
BS-2-J-8	80	1001-056
BS-2A	36	1001-057
BS-2A-J-6	42	1001-058
BS-2A-J-8	49	1001-059

BS-2 (Tail-stock)

Unit:mm/inches.

ORDER NO.	A1	B1	H1	h1	a1	b1	g1
BS-2	205~255 8 5/64~10 5/64	86 3 15/32	139 5 15/32	132.7 5 15/64	175 6 57/64	124 4 7/8	16 5/8
BS-2A	218	74	139	134	175	124	16

ORDER NO.	Gross Weight kg	Meas. CFT	Applicable Chuck
BS-0	(C)20	0.8	5"
BS-1	(C)33	1.3	6"
BS-2	(C)65	3.4	6" OR 8"