

Products Index > VERTEX-TOOLING -SYSTEM-ER-COLLET-DRILL-TAPPING-CHUCK-HOLDER-ARBOR鷹牌搪孔攻牙刀桿 > Reversible Tapping Attachment VTA7-JT6, VTA12-JT6, VTA20-M20正逆轉攻牙器

Category Name : Reversible Tapping Attachment VTA7-JT6, VTA12-JT6, VTA20-M20正逆轉攻牙器

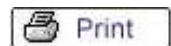
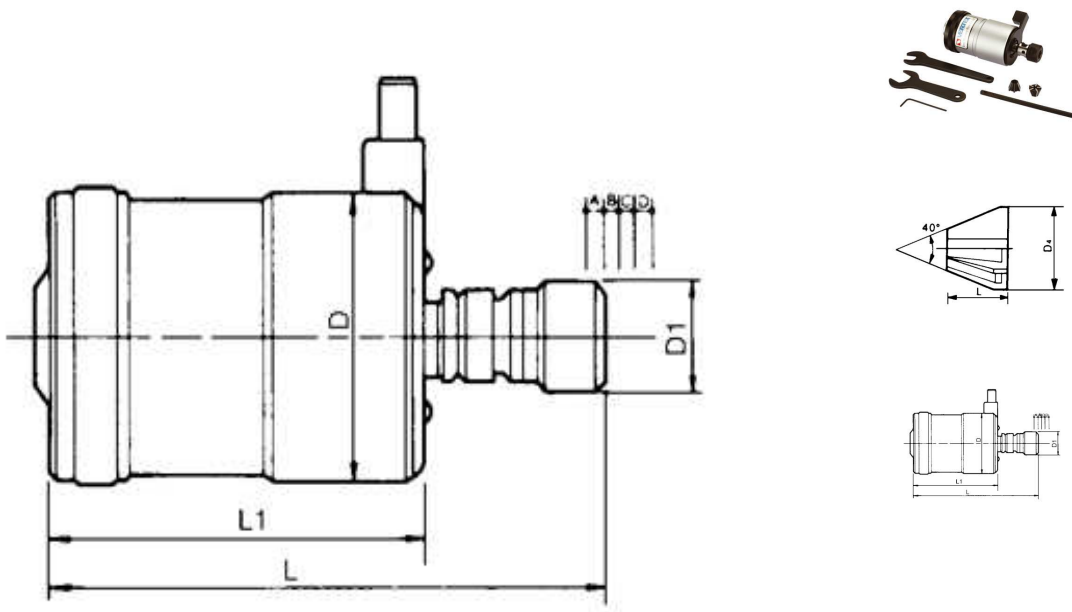

Description

ORDER NO.	SPEED	A	B	C	E	D	D1	L	L1	CAPA CITY	WEIGHT	TYPE	CODE NO.	Inquiry
VTA7-JT6	1500RPM	5	3.5	1.5	7.0	52	23	125.5	94.5	tap M2~M7	1.3	ADAPTER size FC-10/FC-11	3404-020	Inquiry
VTA12-JT6	1000RPM	5	4.5	1.5	8.5	73.5	28	169	122	M3-M12	3.1	ADAPTER size FC-20/FC-21	3404-021	Inquiry
VTA20-M20	600RPM	5.5	5	2.0	9.0	91	38	190	128	M8-M20	5.7	ADAPTER size FC-30/FC-31	3404-022	Inquiry

- Radial Float is SELF-CENTERING to compensate for hole center misalignment.
- Unique Double Spring Mechanism produces Automatic Feed and Cushion Drive. There are two springs for the feed and two springs for the reversal. Each set gives you double smoothness for ULTRA accurate tapping applications(not possible with this type of tapping head in the past).
- Pre-set Torque Control Permits easy operation of tap brake torque control
- JACOBS RUBBER FLEX COLLETS are standard accessory.

VERTEX-Vertex-Mini-Tapping Arm-type-Air Tapping Machine", Air-Tapping Machine", Mini-Tapping", "Arm-Air Tapping", "unit Machine, arm type, "air tapping Arm", Machine, "arm tapping", "AIR TAPPING ARM CHINA", "ARM TAPPING GAIR A R M", arm air tapping Machine, air ARM tapping Machine, Arm type Air Tapping unit Machine, arm type air tapping unit Machine "FlexArm Tapping", & "Torque Arms", "FlexArm", "Tapping", & "Torque", "Arm"s, www.flexaminc.com/"FLEX ARM TAPPING & TORQUE ARMS, www.flexaminc.com/"Pneumatic Tapping Machine", "Hydraulic tapping machine", "Electric tapping machine", "COLETT", "Pneumatic Tapping Machine", "Hydraulic tapping", "MACHINES", "Electric tapping machines, "Hydraulic tapping machines, "Electric tapping machines, and relative accessories, relative accessories: "TAPPING OVERLOAD CHUCK", "TAPPING relative accessories: "TAPPING OVERLOAD CHUCK", "TAPPING COLLET", Accessories: "TAPPING CHUCK" AND READY TO USE FOR ANY TAPPING JOB ON WORKPCE, ACCESSORIES, Air tapping spindle, Parallel arm, Table mounting column, Arm unit, Choose any six safety clutch tapping adapters, Without stand plate VERTEX Mini arm type air tapping unit VTA7-JT6, VTA12-JT6, VTA20-M20 正逆轉攻牙器, Isame, SWIFT AND EASY TO INSTALL AND USE VERY SMOOTHLY, NO LARGE SPRING REQUIRE CHEAPER COST THAN BIGGER TAPPING MACHINE, Application, INSTALL ON FIXED PLATE AND READY TO USE FOR ANY TAPPING JOB ON WORKPCE, ACCESSORIES, Air tapping spindle, Parallel arm, Table mounting column, Arm unit, Choose any six safety clutch tapping adapters, Without stand plate 鷹牌 U2 系列 刀桿 搪孔 攻牙器 由 捷 唯 特 具 有限公司