

NEW

FAST EASY

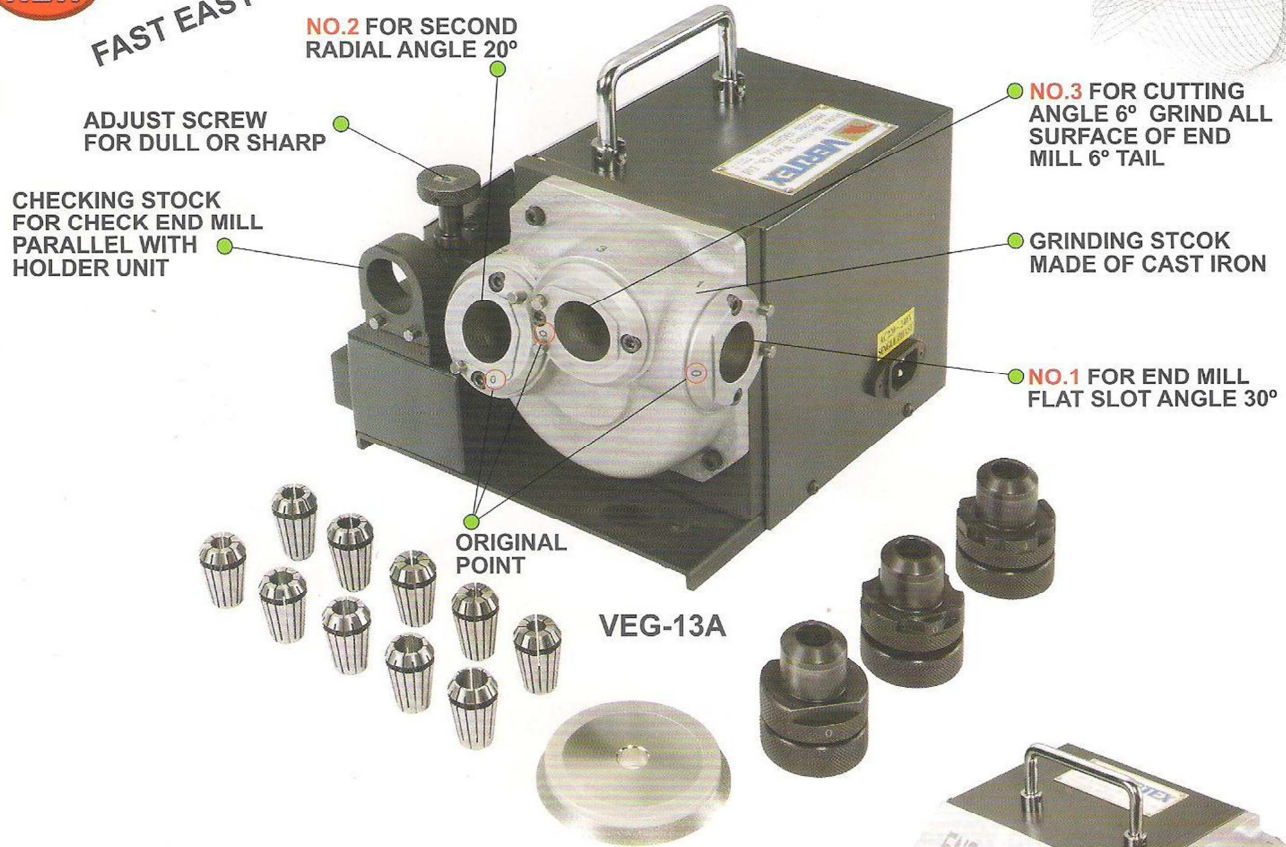

For End Mill Re-sharpening, 2, 3, 4 Number Flute
Precision Efficient, Easy operation,
Short processing time, Grinding Diameter from 4-13 mm.
Reasonable Price, Fast, Rigid, Simplified Step

1. High Efficiency, High Quality Grinding Slip, Good Grinding Results
2. Quality Assurance: $\pm 0.02\text{mm}$, Strong, Reliable, Grinding Stock Won't Bend.
3. Easy Operation, For Urgent Need, Low cost, Save Money

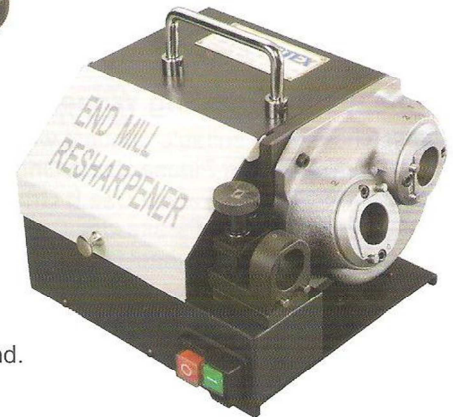

| ORDER NO. | VEG-13A | VEG-25A |
|------------------------|--|--|
| CAPACITY END MILL DIA. | $\phi 4 \sim \phi 13\text{mm}$ | $\phi 12 \sim \phi 25\text{mm}$ |
| MOTOR | 450W | 1000W |
| SPEED | 6000rpm | 4300rpm |
| POWER | AC-110 or 220 1PH 50/60HZ | AC-110 or 220 1PH 50/60HZ |
| AXIAL-ANGLE | NO.1 END MILL FLAT SLOT ANGLE 30° NO.2 SECOND RADIAL ANGLE 20° NO.3 CUTTING ANGLE 6° | NO.1 END MILL FLAT SLOT ANGLE 30° NO.2 SECOND RADIAL ANGLE 20° NO.3 CUTTING ANGLE 6° |
| STANDARD ACCSSORIES | ALLOY STEEL COLLET ER-20 COLLET: $\phi 4, 5, 6, 7, 8, 9, 10, 11, 12, 13\text{mm}$ 10 pcs/set WRENCH:1PC SDC 300 x1 For $\phi 4 \sim \phi 6\text{mm}$ SDC 270 x1 For $\phi 7 \sim \phi 13\text{mm}$ Square Type For 4 Flutes End Mill x 1 Set Hex. Type For 3 Flutes End Mill x 1 Set Parallel Type For 2 Flutes End Mill x 1 Set | ALLOY STEEL COLLET ER-40 COLLET: $\phi 12, 16, 18, 20, 22, 25\text{mm}$ 6 pcs/set WRENCH:1PC SDC 150 x1 For $\phi 12 \sim \phi 25\text{mm}$ Square Type For 4 Flutes End Mill x 1 Set Hex. Type For 3 Flutes End Mill x 1 Set Parallel Type For 2 Flutes End Mill x 1 Set |
| PACKING SIZE | 320x260x300mm | 365x293x345mm |
| WEIGHT (kg) | 17 | 31 |
| CODE NO. | 8001-510A | 8001-520A |

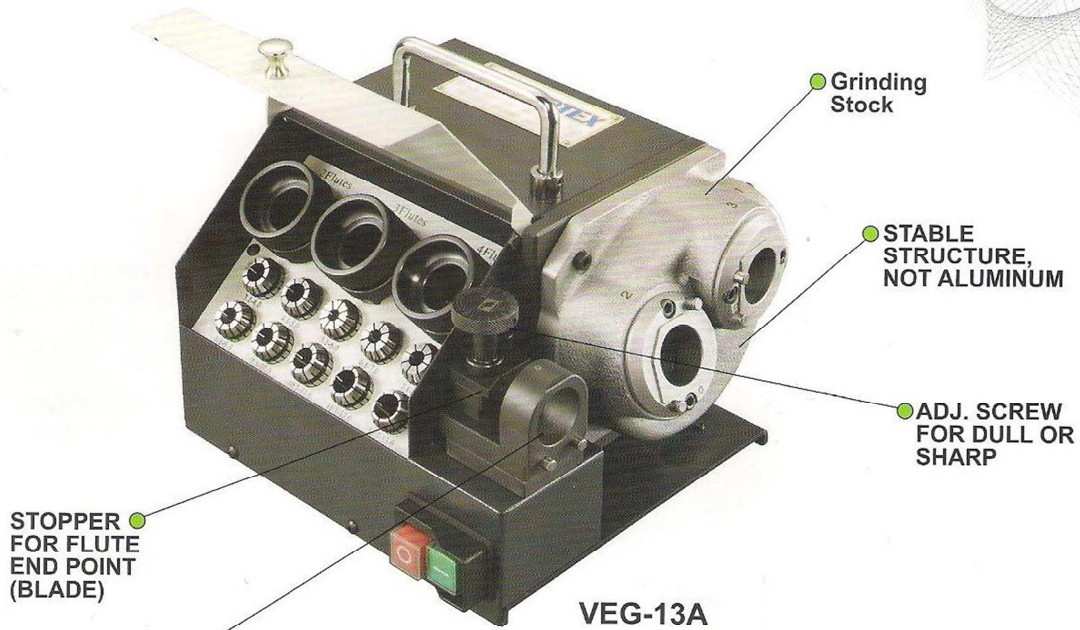

VEG-13A

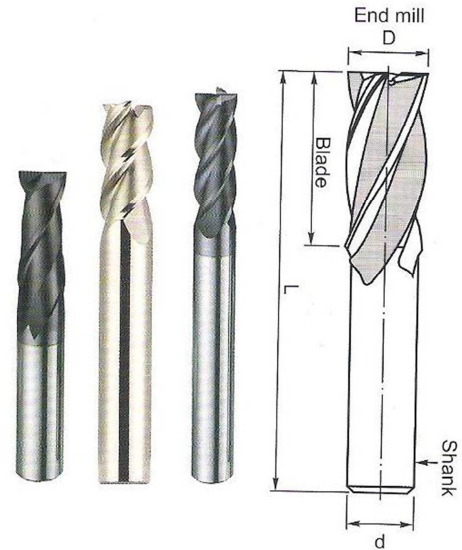
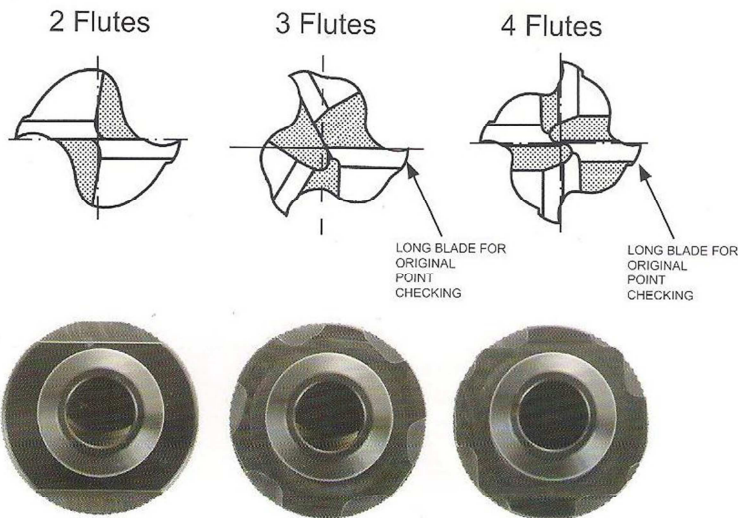
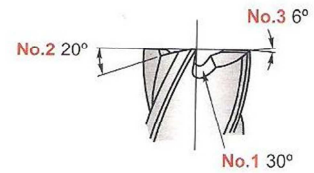

Optional Accessories

※ Each holder unit has mark 2, 3 and 4 on it.

| ORDER NO. | Grind Wheel | FOR END MILL MATERIAL | Weight (kg) | CODE NO. |
|-----------|--|-----------------------|-------------|-----------|
| VEG-13BS | CBN 300 x1 For $\phi 4\sim\phi 6\text{mm}$ | H.S.S. | 0.35 | 8001-511A |
| VEG-13BL | CBN 270 x1 For $\phi 7\sim\phi 13\text{mm}$ | H.S.S. | 0.35 | 8001-512A |
| VEG-13DS | SDC 300 x1 For $\phi 4\sim\phi 6\text{mm}$ | CARBIDE | 0.35 | 8001-514 |
| VEG-13DL | SDC 270 x1 For $\phi 7\sim\phi 13\text{mm}$ | CARBIDE | 0.35 | 8001-515 |
| VEG-25BS | CBN 150 x1 For $\phi 12\sim\phi 25\text{mm}$ | H.S.S. | | 8001-516 |
| VEG-25DS | SDC 150 x1 For $\phi 12\sim\phi 25\text{mm}$ | CARBIDE | | 8001-517 |