

- 此顶针使用深沟球轴承及平面推力轴承组合
- 适用于中速中轻载使用
- 心轴采用合金工具钢,经热处理(HRC60° ± 2°),具有高钢性及耐磨性.
- Center is assembled with bearing and plane thrust bearing
- Can be used at medium speed
- The shaft is made of alloy steel and through heat treatment HRC 60° ± 2° ,it processes super steel trait and high durability.

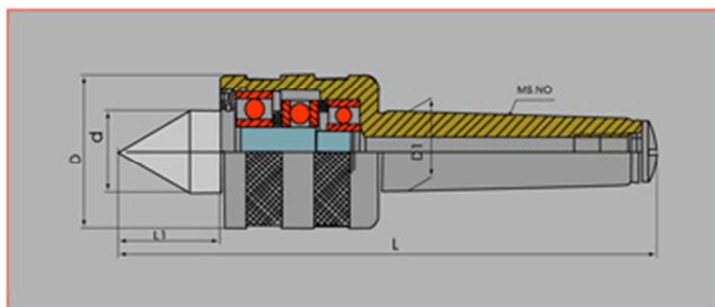

工厂编号 (Art.NO)	型号 (Model)	MS.NO	L (mm)	D (mm)	L1 (mm)	d (mm)	D1 (mm)	径向载荷 (N) Max Load	极限转速 (rpm) Max speed	精度 Accuracy(mm)
003090	D411	1	115	34	20	18	12.065	900	5000	0.01
003091	D412	2	145	45	26	25	17.780	1500	5000	0.01
003092	D413	3	170	52	30	28	23.825	2000	4200	0.01
003093	D414	4	205.7	60	34.7	32	31.267	3200	3200	0.01
003094	D415	5	254	77	45	45	44.399	3600	1000	0.015
003095	D416	6	362	125	68.5	75	63.348	10000	800	0.015