

DIAL TEST INDICATOR

JEWELLED BEARING



2380-08

- Jeweled bearing
- Carbide contact point
- Two measuring directions
- Anti magnetic body
- Supplied with two clamps: diameter Ø4mm and Ø8mm
- Optional accessory: styli (page 138)

Unit: mm

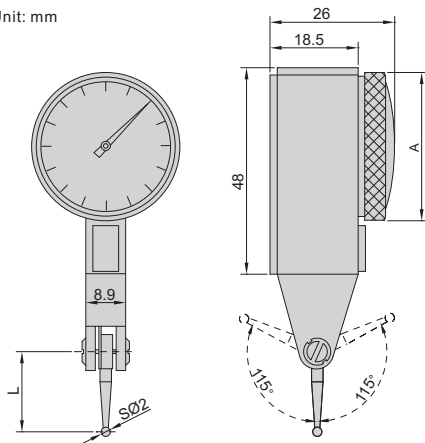

(mm)

Code	Range	Graduation	Accuracy	Hysteresis	Dial reading	A	L
2380-08*	0.8mm	0.01mm	13µm	3µm	0-40-0	Ø30	16.5
2381-08*	0.8mm	0.01mm	13µm	3µm	0-40-0	Ø37.5	16.5
2380-02*	0.2mm	0.002mm	6µm	2µm	0-100-0	Ø30	16
2381-02*	0.2mm	0.002mm	6µm	2µm	0-100-0	Ø37.5	16

* Supplied with manufacturer calibration certificate

clamps

